

THIS DRAWING IS UNPUBLISHED. RELEASED FOR PUBLICATION, 19 .
 © COPYRIGHT 19 BY AMP INCORPORATED. ALL INTERNATIONAL RIGHTS RESERVED.

LOC	DIST	P	F	REVISIONS				
AF	50			ZONE	LTR	DESCRIPTION	DATE	APPD
				L		REL PER 063A-0250-02	15MAY02	JR/KR

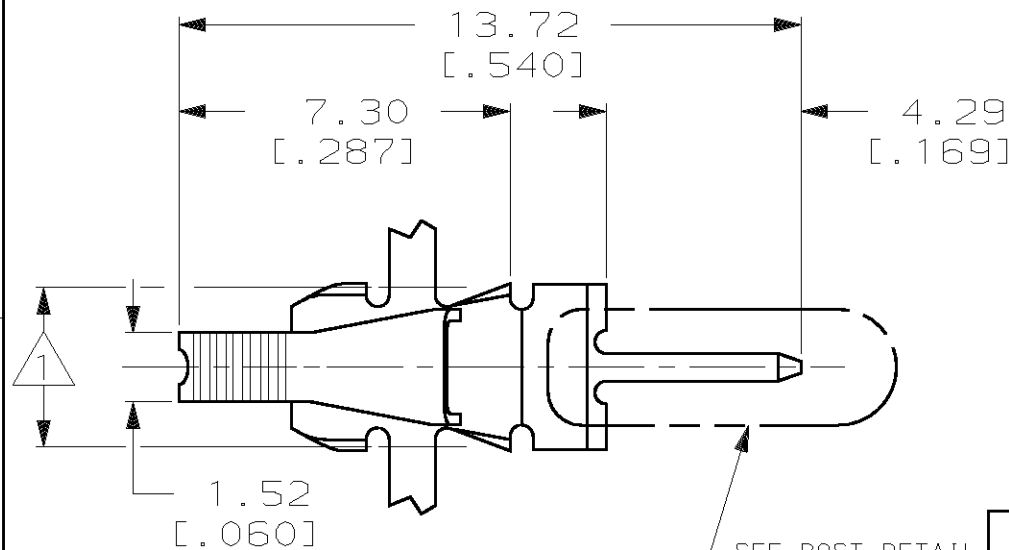

4 DIMENSIONS OF SECTION Y-Y APPLY IN ZONE Z ONLY.

6 DIMENSION APPLIES IN ZONE X ONLY.

- 1 3.78±0.13 [.149±.005] APPLICATOR CUT-OFF.
- 2 CONTINUOUS STRIP ON REELS WITH TERMINALS LOCATED ON 6.10±0.08 [.240±.003] CENTERS.
- 3 IDENTIFICATION NUMBER 18 FOR MAGNET WIRE RANGE.

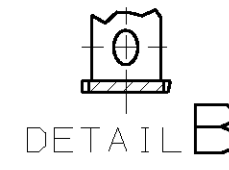
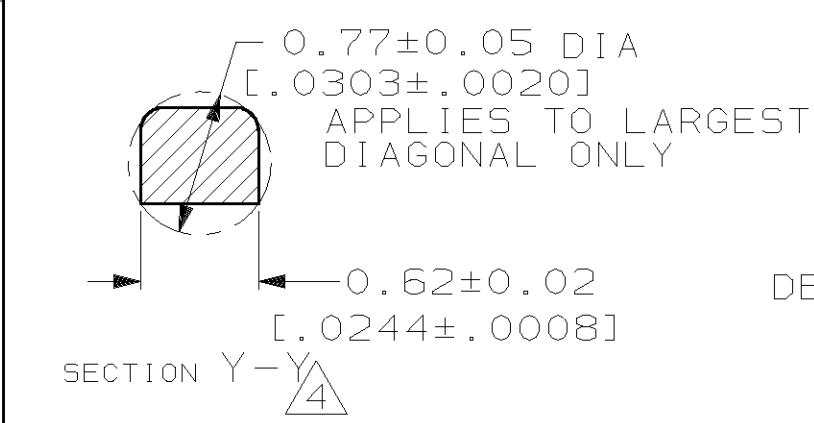
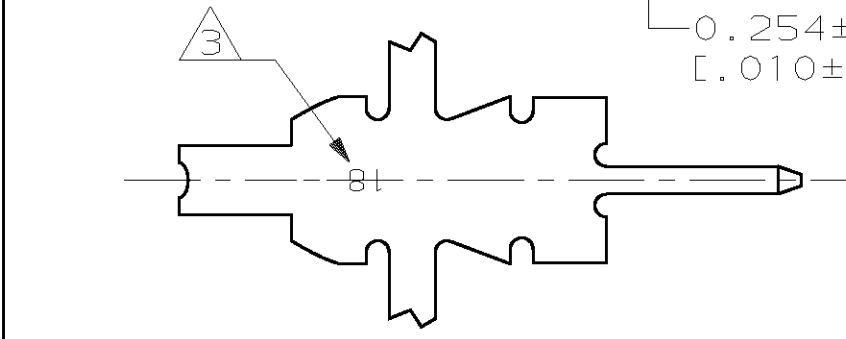
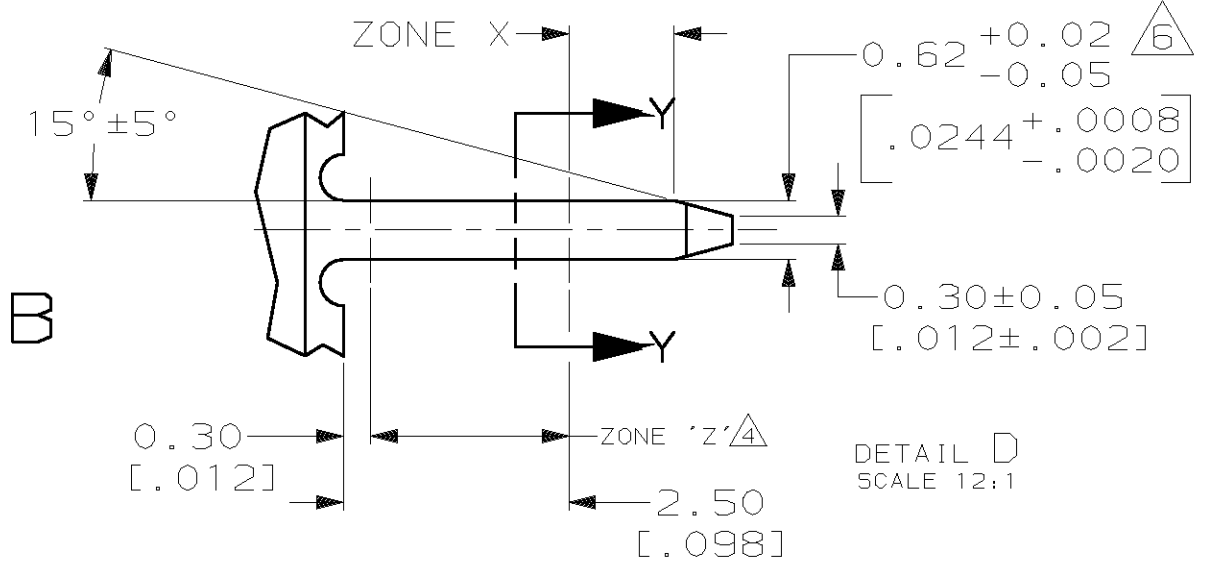
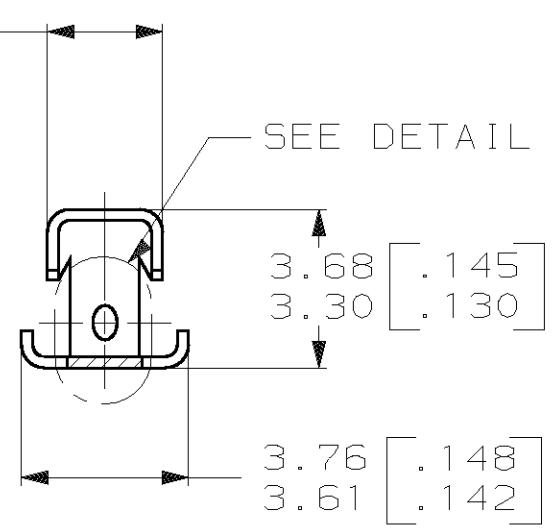
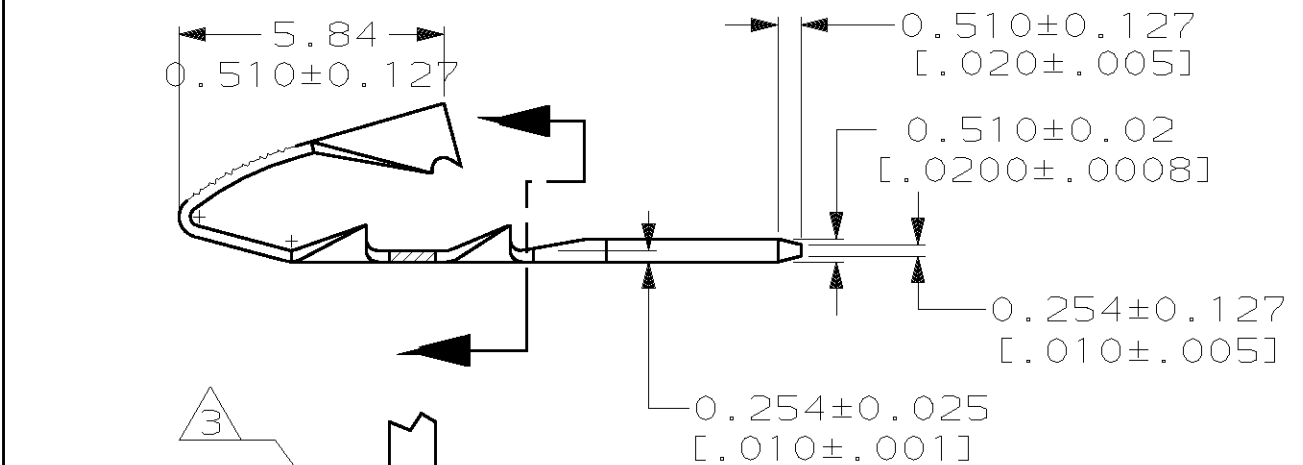

	0.10-0.25mm [#38-#30] AWG	H04 PRE-MILLED PHOS. BRONZE	63675-4
OBSOLETE	0.10-0.25mm [#38-#30] AWG	H04 PRE-MILLED PHOS. BRONZE	63675-3
OBSOLETE	0.10-0.25mm [#38-#30] AWG	H04 PRE-MILLED PHOS. BRONZE	63675-2
OBSOLETE	0.10-0.25mm [#38-#30] AWG	H02 PRE-MILLED BRASS	63675-1
	MAGNET WIRE RANGE	MATERIAL	PART NO

DO NOT SCALE PRINT. UNLESS SPECIFIED DIMENSIONS IN mm [INCHES] TOLERANCES ON: 2 PLC DEC ± 0.25 [.010] 3 PLC DEC ± - ANGLES ± 1°	DR 10/6/92 MICHAEL S. FEHER CHK 10/7/92 JEFF R. RUTH APPD 10/12/92 NELSON E. NEFF APPD 10/12/92 TERRY L. SHUTTER
MATERIAL SEE ABOVE	PRODUCT SPEC 108-2016
FINISH 0.001016 [.000040] MIN TIN PLATE	APPLICATION SPEC 114-2047
	WEIGHT -

AMP Incorporated Harrisburg, PA 17105-3608		
NAME POST, 0.62 [.024] X 0.51 [.020], MINI MAG-MATE™		
SIZE B	CAGE CODE 00779	DRAWING NO C-63675
SCALE 6:1	SHEET 1 OF 1	

THIS DRAWING IS A CONTROLLED DOCUMENT FOR AMP INCORPORATED. IT IS SUBJECT TO CHANGE AND THE CONTROLLING ENGINEERING ORGANIZATION SHOULD BE CONTACTED FOR THE LATEST REVISION.